

1,000ml White BioBoard Takeaway Base BB-LB-1000-W

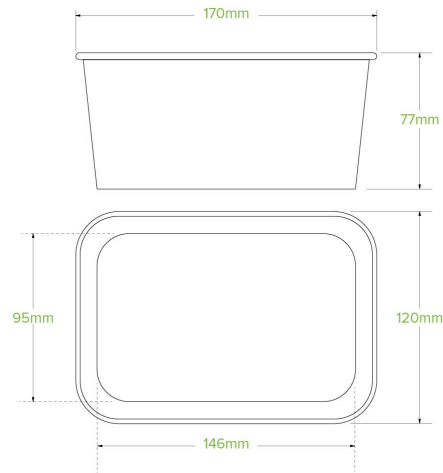

BioBoard Rectangular Paper Containers are sustainably sourced and made from FSC™ certified paper board. These eco-friendly food containers are lined with a bioplastic made from plants, not oil, and certified industrially compostable. This food packaging is perfect for hot and greasy food.

Carton quantity: 300	Sleeves per carton: 6	Units per sleeve: 50
Carton Size LxWxH (cm): 38x36x47.5	Carton gross weight (kg): 7.100000	Carton barcode: 19344062067815
Raw Material: Paper - FSC™ Mix certified paper	Lining/coating: Bioplastic - PLA	Window Material: None
Printing Type: Flexo	Inks: Food Contact Safe Inks	Brim fill capacity (ml): 1070
Dimensions top LxW (mm): 172x120	Dimensions base LxW (mm): 146x95	Product Depth: 75
Thickness: 350gsm	Use: Hot, Cold, Wet & Dry Products	Manufactured: China
Customise: Print	MOQ custom: 50000	Mould fees: Yes - see custom packaging
Home compostable: No	Industrially compostable: Certified to AS4736 Australian Standards, Certified to EN13432 European Standard	Recyclable: No